

Pressalit Zaga, incl. UN9 univertical hinge

No. 314xxx-UN9999 with cover

Design/Year

Pressalit, 2001, registered design

Product Description

PRESSALIT toilet seat with cover, model "Zaga", art. no. 314 made of colour ingrained duroplast with stainless steel hinges.

- with UN9 univertical hinge
- centre distance: 155 mm
- soft, pleasant and well-balanced appearance with rounded edges
- load - ring seat 240 kg
- with inlaid duroplast hinges for easier cleaning
- suitable for many universal toilets
- 10 year guarantee

Colour Programme

000 white, 001 black, 011 white polygiene, 052 manhattan, 273 pergamon,

Alternative Hinge

D46 Top mounted hinge
BN9 Universal hinge

Hinge Finish

999 Stainless steel

Spare Parts

A4023 Buffer for pushing into cover, oval, grey,
A4023000 white, A4023273 pergamon
A4033 Buffer for pushing into seat, oval, grey,
A4033000 white, A4033273 pergamon
A9153 Set of straps (screw-in), grey,
A9153000 white, A9153273 pergamon

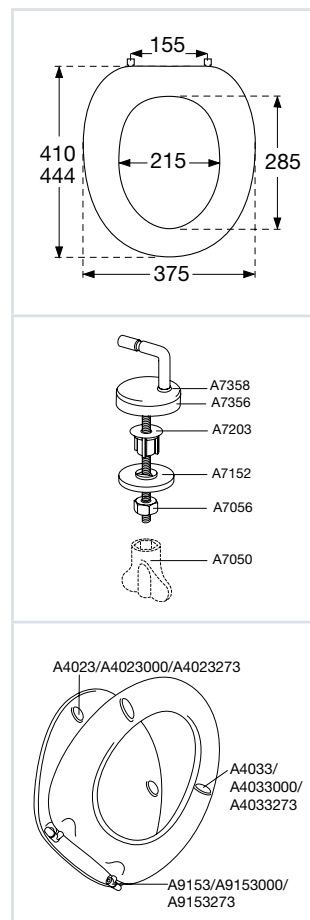

A seat with a retro-touch, encompassing the best from previous Pressalit classics - and adding some brand new features. Soft and rounded forms, even the edges are round. The new hinge-links of nylon are invisibly mounted, thus leaving the inner sides of the seat and cover with nothing but an even, smooth hygienic surface. Large colour programme.

Product Weight	Net weight approx. 3,000 kg, incl. hinge		
Packaging	Single carton 5 single cartons in a master carton 18 master cartons (90 seats) per pallet	Dimensions: 449x381x64 mm 456x388x340 mm	Weight: 3,400 kg 17,500 kg
Material Description	<p>Toilet seat: The material is colour ingrained duroplast (UF A 10 = urea formaldehyde) that contains no environmentally hazardous substances. UF plastic comprises 67% urea formaldehyde resin, 28% cellulose, as well as 5% minerals, pigments, lubricants and moisture content. The raw material from the supplier contains up to 0.03% free formaldehyde and even less following curing.</p> <p>Buffers: EVA (copolymer made of ethylene and vinyl acetate).</p> <p>Hinge links: Zytel, PA6.6 with 25% glass (nylon).</p> <p>Mount/hinges: Stainless steel (V2A) model W. no. 1.4301/M in accordance with DIN 17441/85. Composition: chrome (cr) 17-19%, nickel (ni) 8-11%, carbon <0.05%, molybdenum, manganese, silicone, sulphur, titanium.</p>		
Suitability List	Usable on universal toilets - see www.pressalit.com		
Cleaning Instructions	<p>Use a mild soap solution to clean the seat. Please take care that the seat and hinges are not left damp. Dry off any residual water or cleaning agent with a soft cloth. Avoid contact of the seat and hinges with abrasive, corrosive or chlorine-based cleaners, as these may cause damage or lead to flash rust. Therefore, when cleaning the bowl, make sure that the seat and cover are kept in an upright position until all cleaning agent has been flushed away.</p> <p>The guarantee includes faults or defects in the material of our products within a period of 10 years. Products subject to minor technical modifications and design deviations E. & O.E.</p>		



www.pressalit.com

European Sales Agencies
Unit 10c Tanfield Lea (North) Industrial Estate
Tanfield Lea, Stanley
Co Durham, DH99UU
Tel. 01207 236622, Fax 01207 236633
info@europeansalesagencies.com
www.europeansalesagencies.com

Pressalit A/S
Pressalitvej 1
DK-8680 Ry
Tel. (+45) 8788 8788
Fax (+45) 8788 8789
pressalit@pressalit.com

PRESSALIT®
seats