

Pressalit 2000®, incl. UN3 univertical hinge

No. 124xxx-UN3999 with cover
No. 49000-UN3999 without cover

Design/Year

Pressalit, 1991, registered trade mark

Product Description

PRESSALIT toilet seat with cover, model "2000", art. no. 124 made of colour ingrained duroplast with stainless steel hinges.

- with UN3 univertical hinge of stainless steel
- centre distance: 155 mm
- load - ring seat 240 kg
- suitable for many universal toilets
- also with institutional hinges on request (objecta seat)
- 10 year guarantee

Colour Programme xxx

With cover: 000 white, 001 black (RAL 9005), 013 bahamabeige, 052 manhattan, 273 pergamon
Without cover: 000 white

Alternative Hinges

With cover:

- BN3 Universal hinge
- BV7 Institutional hinge, universal
- BY5 Institutional hinge, fixed
- D07 Universal hinge for Sphinx Wandklosett 48 cm
- D43 Top mounted hinge
- UN4 Univertical toogle hinge

Without cover:

- BA1 Fixed hinge
- BV5 Institutional hinge, universal
- BY3 Institutional hinge, fixed

Hinge Finish

999 Stainless steel

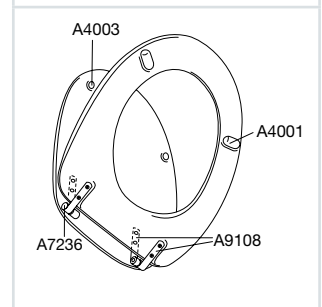
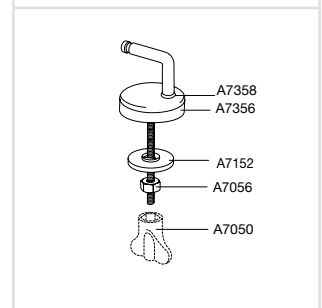
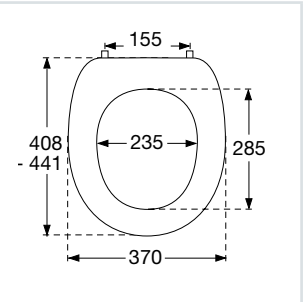

Pressalit 2000. Light and elegant design. A slightly smaller cover on top of a full-size ring.

Spare Parts

A4001	Buffer for pushing into seat, oval, grey
A4003	Buffer for pushing into cover, round, grey
A7236	Clamp bush, grey
A7250	Axle bushing
A9108	Set of straps and screws, stainless steel

Product Weight

Net weight approx. 2,600 kg, incl. hinge

Packaging

Single carton	Dimensions:	Weight:
5 single cartons in a master carton	449x381x64 mm	2,900 kg
18 master cartons (90 seats) per pallet	456x388x340 mm	15,000 kg

Material Description

Toilet seat:

The material is colour ingrained duroplast (UF A 10 = urea formaldehyde) that contains no environmentally hazardous substances. UF plastic comprises 67% urea formaldehyde resin, 28% cellulose, as well as 5% minerals, pigments, lubricants and moisture content. The raw material from the supplier contains up to 0.03% free formaldehyde and even less following curing.

Buffers:

EVA (copolymer made of ethylene and vinyl acetate).

Hinge links:

Stainless steel (V2A) model W. no. 1.4301/M in accordance with DIN 17441/85.
Composition: chrome (cr) 17-19%, nickel (ni) 8-11%, carbon <0.05%, molybdenum, manganese, silicone, sulphur, titanium.

Mount/hinges:

Stainless steel (V2A) model W. no. 1.4301/M in accordance with DIN 17441/85.
Composition: chrome (cr) 17-19%, nickel (ni) 8-11%, carbon <0.05%, molybdenum, manganese, silicone, sulphur, titanium.

Suitability List

Usable on universal toilets - see www.pressalit.com

Cleaning Instructions

Use a mild soap solution to clean the seat. Please take care that the seat and hinges are not left damp. Dry off any residual water or cleaning agent with a soft cloth. Avoid contact of the seat and hinges with abrasive, corrosive or chlorine-based cleaners, as these may cause damage or lead to flash rust. Therefore, when cleaning the bowl, make sure that the seat and cover are kept in an upright position until all cleaning agent has been flushed away.

The guarantee includes faults or defects in the material of our products within a period of 10 years. Products subject to minor technical modifications and design deviations E. & O.E.



Pressalit A/S, Denmark



www.pressalit.com

European Sales Agencies
Unit 10c Tanfield Lea (North) Industrial Estate
Tanfield Lea, Stanley
Co Durham, DH99UU
Tel. 01207 236622, Fax 01207 236633
info@europeansalesagencies.com
www.europeansalesagencies.com

Pressalit A/S
Pressalitvej 1
DK-8680 Ry
Tel. (+45) 8788 8788
Fax (+45) 8788 8789
pressalit@pressalit.com

PRESSALIT®
seats